



NZBC Clause B1 Structure - Design

Aluminium Canopies and Window Frames

Project number: 23040127-01A

Company name: Aurae Ltd

Date: 14/04/2023 **Expiry:** 14/04/2024

Location: All regions within NZ considered a high wind zone or below, and all sub-alpine snow regions with NZ as per this report's parameters

Victoria Park Market, Unit 72B, 210 Victoria Street,
Auckland 1010, New Zealand.

p: +64 9 216 7104

e: info@teambrevity.com

All information, details or designs portrayed in this document remain copyright of Brevity Ltd (unless brevity has expressly agreed otherwise with the Client). Any reproduction without the express permission of Brevity Ltd is prohibited.

This report has been prepared by Brevity on the specific instructions of our Client. It is solely for our Client's use for the purpose for which it is intended in accordance with the agreed scope of work. Any use or reliance by any person contrary to the above to which Brevity has not given its prior written consent, is at that person's risk.



Building Code Clause(s) B1

PRODUCER STATEMENT – PS1 – DESIGN

(Guidance on use of Producer Statements (formerly page 2) is available at www.engineeringnz.org)

ISSUED BY: Brevity Ltd
(Design Firm)

TO: Aurae Ltd
(Owner/Developer)

TO BE SUPPLIED TO: Building Consent Authority
(Building Consent Authority)

IN RESPECT OF: Brevity report # 23040127-01A Design of Non-Structural Building Elements
(Description of Building Work)

AT: Various locations in New Zealand, excluding lee zones and high snow regions - Refer attached report
(Address)

Town/City: **LOT** **DP** **SO**
(Address)

We have been engaged by the owner/developer referred to above to provide:
Design Consultancy for seismic restraint of non-structural building elements

(Extent of Engagement)

services in respect of the requirements of Clause(s) B1 of the Building Code for:

All or Part only (as specified in the attachment to this statement), of the proposed building work.

The design carried out by us has been prepared in accordance with:

Compliance Documents issued by the Ministry of Business, Innovation & Employment B1/VM1 or
(verification method/acceptable solution)

Alternative solution as per the attached schedule.....

The proposed building work covered by this producer statement is described on the drawings titled:
Canopy and Window Hood Standard Fixing Detail and numbered IN-STDDC-1.1, IN-STDDC- 1.2, IN-STDDC-1.3 & STDWH- 1.1, STDWH- 1.2, STDWH- 1.3;
together with the specification, and other documents set out in the schedule attached to this statement.

On behalf of the Design Firm, and subject to:

- (i) Site verification of the following design assumptions see attached report - #16121908
- (ii) All proprietary products meeting their performance specification requirements;

I believe on reasonable grounds that a) the building, if constructed in accordance with the drawings, specifications, and other documents provided or listed in the attached schedule, will comply with the relevant provisions of the Building Code and that b), the persons who have undertaken the design have the necessary competency to do so. I also recommend the following level of construction monitoring/observation:

CM1 CM2 CM3 CM4 CM5 (Engineering Categories) or as per agreement with owner/developer (Architectural)

I, Matt Bishop am: CPEng 243276 # Reg Arch #
(Name of Design Professional)

I am a member of: Engineering New Zealand NZIA and hold the following qualifications: BE (Hons)

The Design Firm issuing this statement holds a current policy of Professional Indemnity Insurance no less than \$200,000*.

The Design Firm is a member of ACENZ:

SIGNED BY: Matt Bishop (Signature) 
(Name of Design Professional)

ON BEHALF OF Brevity Ltd Date: 17 APRIL 2023
(Design Firm)

Note: This statement shall only be relied upon by the Building Consent Authority named above. Liability under this statement accrues to the Design Firm only. The total maximum amount of damages payable arising from this statement and all other statements provided to the Building Consent Authority in relation to this building work, whether in contract, tort or otherwise (including negligence), is limited to the sum of \$200,000*.

This form is to accompany **Form 2 of the Building (Forms) Regulations 2004** for the application of a Building Consent.
THIS FORM AND ITS CONDITIONS ARE COPYRIGHT TO ACENZ, ENGINEERING NEW ZEALAND AND NZIA

1. Overview

This report is a detailed document defining the structure's design criteria and recording key decisions or outcomes. It outlines design loading, structural modelling assumptions, material properties, foundation requirements and design standards. This report also defines the calculation procedure and checking principles to be followed, providing a clear explanation of the full design.

2. Means of Compliance

The design of the structures are in compliance with the New Zealand Building Code (NZBC), section B1. The following standards have been used:

- AS/NZS 1170: 2001
- AS 1664.1: 1997
- NZS 3603: 1993
- NZS 3604: 2011

3. The Structure General

Three structure types have been assessed under the loading requirements of AS/NZS 1170:2001:

- 1) Aluminium sheet metal canopies fixed back to the structure with M8 Stainless Steel Rod.
- 2) Aluminium 200x50x3 RHS or Solaris 200 Louvre window frames
- 3) Aluminium Balustrade, consisting of 100x50x3RHS frame and 50 SHS balusters

The design life of the structures is 50 years.

4. Location

The structures can be located in all regions within NZ considered a high wind zone or below, and all sub-alpine snow regions with NZ as per section 5.4 of this report.

5. Design Actions

5.1 Load Cases

LC1:	1.2G + Wu	(ULS Wind downforce)
LC2:	0.9G + Wu	(ULS Wind uplift)
LC3:	1.2G + 1.5Q	(ULS Balustrade loading)
LC4:	1.2G + Su	(ULS Snow loading)

5.2 Wind Actions

Wind Zone: High

V_{Des} : 37.35 ms⁻¹

C_{fig_canopy} : 0.5

C_{fig_frames} : 1.99

C_{dyn} : 1.0

P_{ULS_Canopy} : 419 Pa

P_{ULS_Frames} : 1667 Pa

5.3 Balustrade Loading

Q _{Point} :	600 N (in any direction)
Q _{UDL} :	0.75 kN/m (on balustrade top rail)
Q _{press} :	1 kPa (on all balustrade members)

5.4 Snow Loading (Sub-alpine regions only)

h _{0,max} :	100 m
k _P :	1.25 (APoE 1/150)
Pitch:	0 degrees
mu _i :	0.84
S _g :	0.9 kPa
S _{ULS} :	0.756 kPa

6. Specifications

All standards stated are the latest versions available at the time of design:

- All workmanship to comply with with NZS 3404.1, AS/NZS 1665, AS/NZS 1554
- All cold formed steel sections to AS/NZS 1163 - G350
- All hot rolled steel plate to AS/NZS 3678 - G250
- All aluminium alloy sections to AS/NZS 1866

7. Proprietary Items

The following proprietary items have been specified as part of this project:

- 10G Stainless Tek Screws
- 14G Stainless Tek Screws
- M8 Coach bolt
- M6 CSK Screws
- 3.2mm S/S Rivets
- RHS/Louvre clasp bracket
- 50mm Square Balusters
- Corner staking angle extrusions

Appendix A - Supporting Calculations

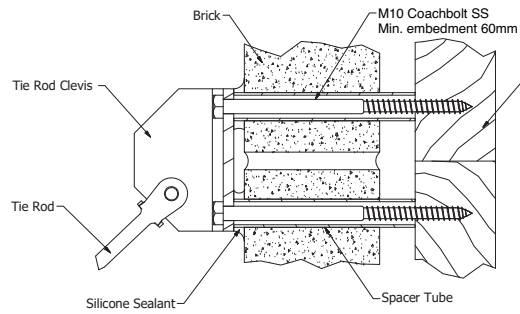

Detail A 1:1.5
 Tie Rod Clevis to Brick Fixing Detail

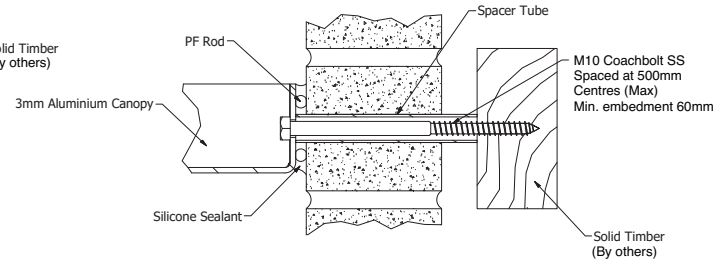

Detail B 1:1.5
 Canopy to Brick Fixing Detail

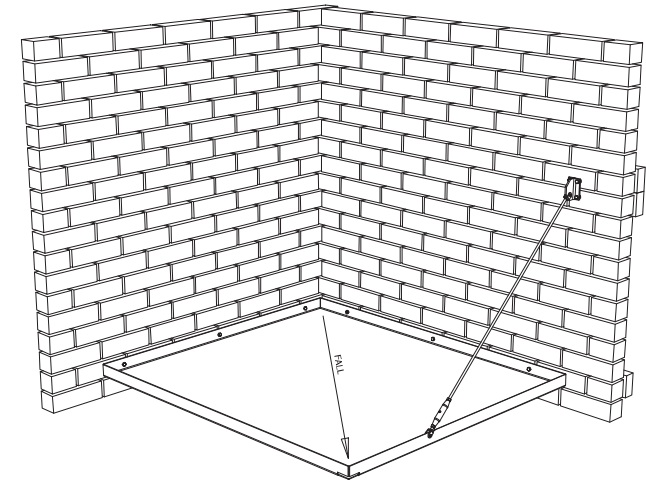

Rear and Side Fix N.T.S

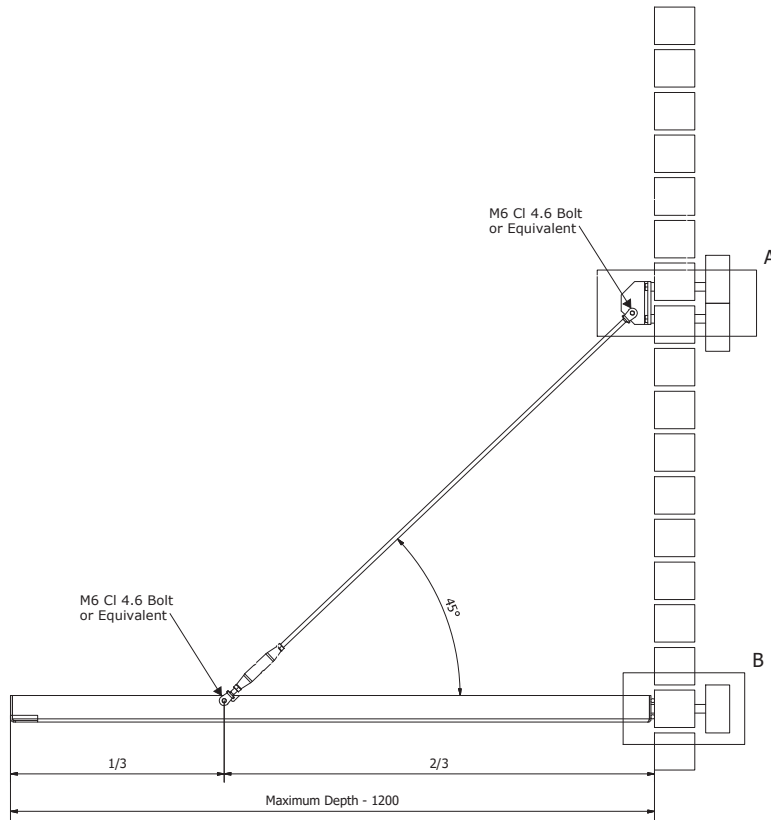

Side Elevation 1:5
 Tie Rod Clevis to Brick Fixing Detail
 Maximum Canopy Width 1500mm

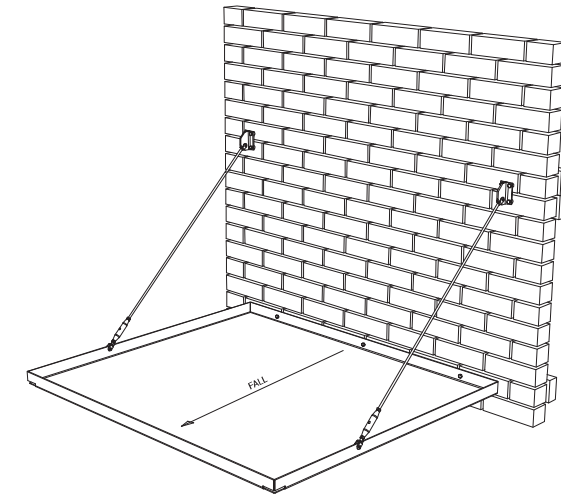

Rear Fix N.T.S

Revision Table			
Rev	Description	By	Date

Tolerance:
Dimension Decimal Places:
 0 = +/- 1mm
 0.0 = +/- 0.1mm
 Angle = +/- 1°

*Unless otherwise stated. Do not scale. If in doubt ask.

File:
 C:\Users\INSOL\Dropbox (Insol Ltd)\Insol\Product Information\Standard Details\Inventor Models\Fletcher Living Door Canopy Fixing.lam

Third Angle



All dimensions are in mm unless otherwise stated

Material: N/A
 Weight:
 Finish:
 Qty Req as Shown:
 Qty Req Opp Hand:



INSOL Architectural
 Aluminium Louvres
 P O Box 231, Invercargill
 Free 0800 34 6000
 Ph 216 3287
 Fax 03 216 5928
 www.insolnz.co.nz

Title:
 Canopy Standard Fixing Detail

Desc:
 Brick Rear Fixed and Rear / Side Fixed

Drawing No:	IN-1 -STDDC-1.1	Rev:	A
Org Date:	21/02/2017	Dwg By:	DM
App By:	DM	Scale:	1:10
Project No:	STDDC		A1

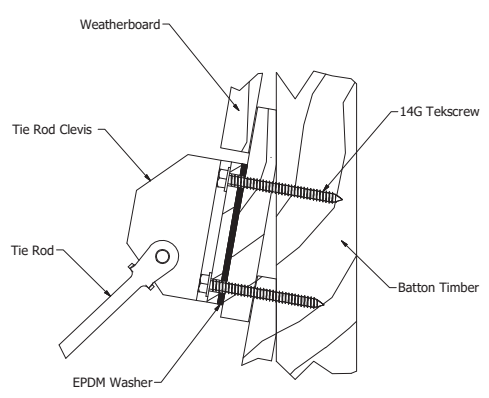

Detail A 1:2.5
 Tie Rod Clevis to Weatherboard Fixing Detail

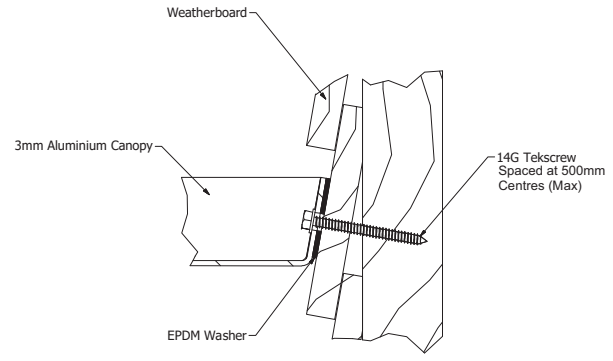

Detail B 1:2.5
 Canopy to Weatherboard Fixing Detail

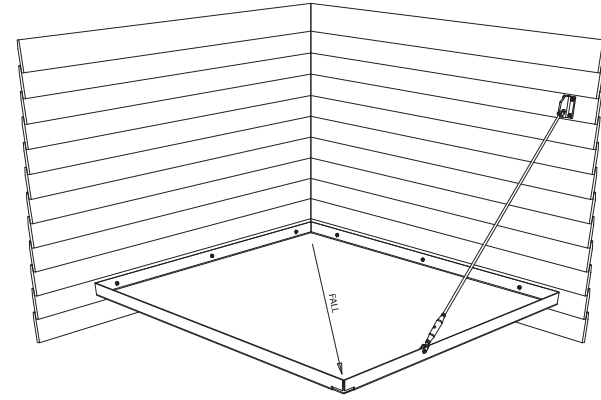

Rear and Side Fix N.T.S

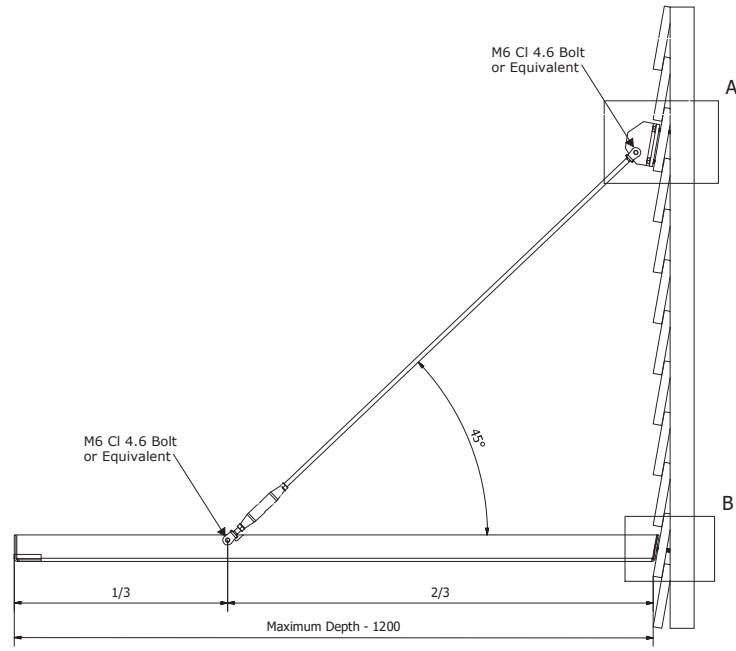

Side Elevation 1:5
 Tie Rod Clevis to Weatherboard Fixing Detail
 Maximum Canopy Width 1500mm

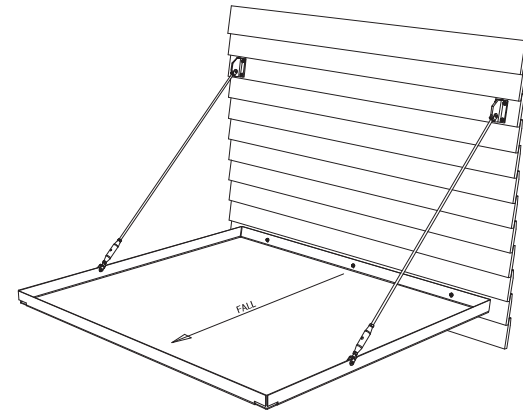

Rear Fix N.T.S

Revision Table			
Rev	Description	By	Date

Tolerance:
Dimension Decimal Places:
 0 = +/- 1mm
 0.0 = +/- 0.1mm
 Angle = +/- 1°

*Unless otherwise stated. Do not scale. If in doubt ask.

File:
 C:\Users\INSOL\Dropbox (insol Ltd)\insol\Product Information\Standard Details\Inventor Models\Fletcher Living Door Canopy Fixing Weatherboard.ipt

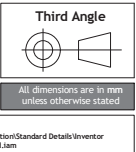

Material: N/A
 Weight: N/A
 Finish: N/A
 Qty Req as Shown:
 Qty Req Opp Hand:

INSOL Architectural Aluminium Louvres

P O Box 231, Invercargill
 Free 0800 34 6000
 Ph 216 3287
 Fax 03 216 5928
www.insolnz.co.nz

Title:
Canopy Standard Fixing Detail

Desc:
Weatherboard Rear Fixed and Rear / Side Fixed

Drawing No: IN-1 -STDDC-1.2
Rev: A

Org Date: 21/02/2017
Dwg By: DM **App By:** DM

Scale: 0.11 : 1

Project No: STDDC **A1**

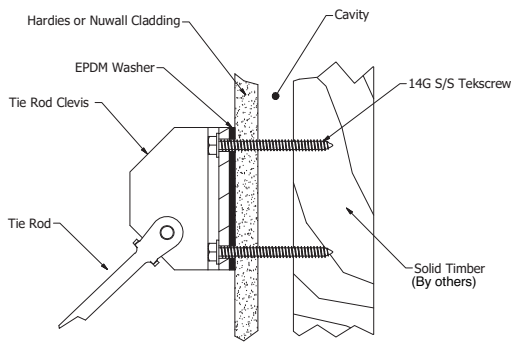

Detail A 1:2.5
Tie Rod Clevis Fixing Detail

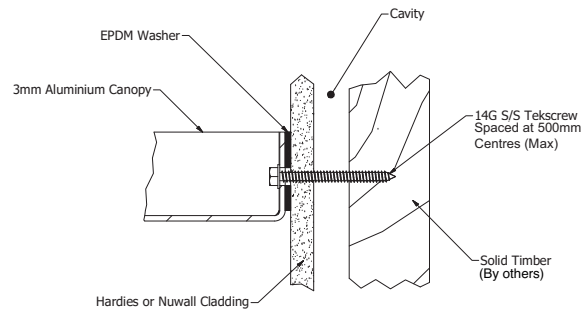

Detail B 1:2.5
Canopy Fixing Detail

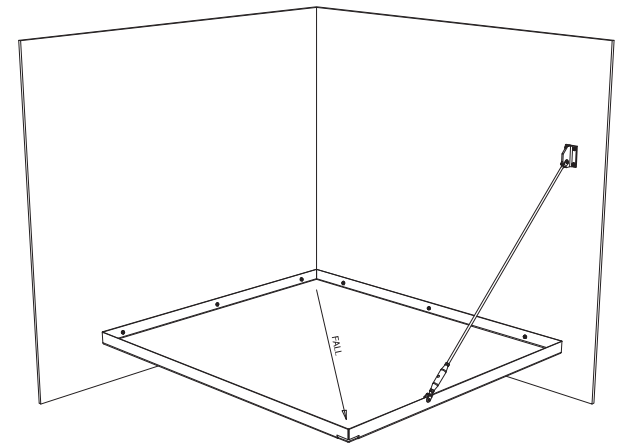

Rear and Side Fix N.T.S

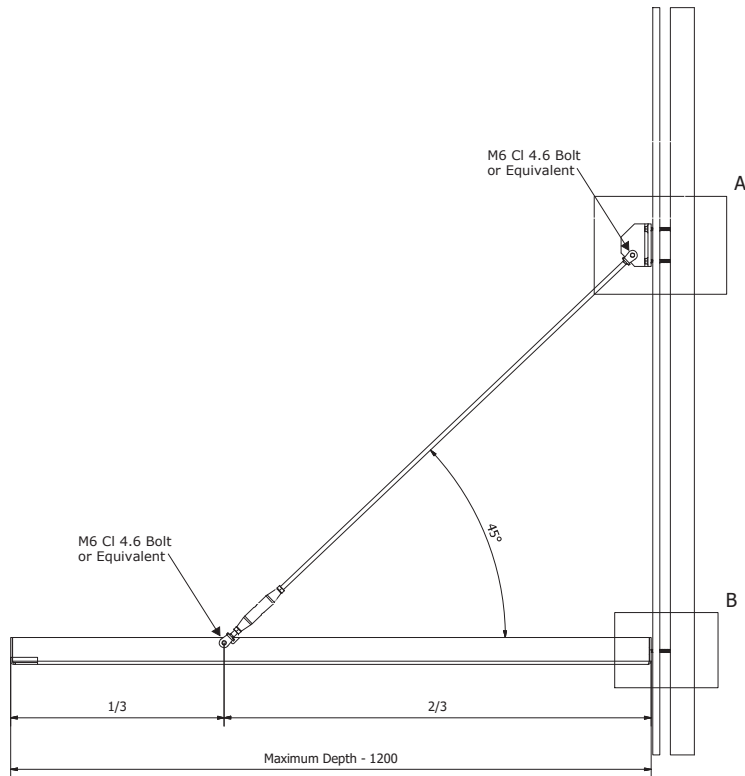

Side Elevation 1:5
Tie Rod Clevis Fixing Detail

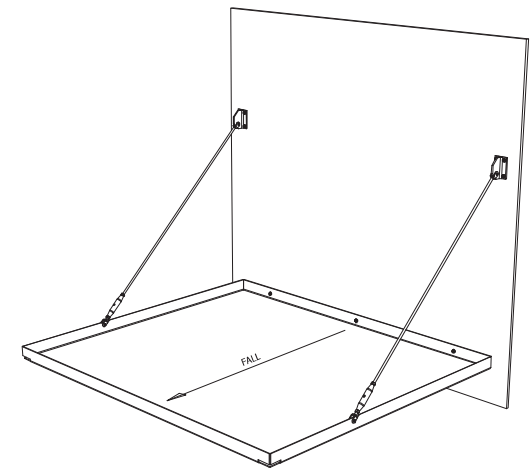

Rear Fix N.T.S

Revision Table			
Rev	Description	By	Date

Tolerance:
Dimension Decimal Places:
 0 = +/- 1mm
 0.0 = +/- 0.1mm
 Angle = +/- 1°
*Unless otherwise stated. Do not scale. If in doubt ask.

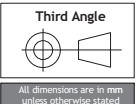

Material: N/A
 Weight:
 Finish:
 Qty Req as Shown:
 Qty Req Opp Hand:

INSOL Architectural Aluminium Louvres
 P O Box 231, Invercargill
 Free 0800 34 6000
 Ph 216 3287
 Fax 03 216 5928
www.insolnz.co.nz

Title:
Canopy Standard Fixing Detail

Desc:
Hardies / Nuwall Rear Fixed and Rear / Side Fixed

Drawing No: IN-I -STDDC-1.3
Rev: A

Org Date: 21/02/2017
Dwg By: DM **App By:** DM
Scale: 1:5
Project No: STDDC **A1**

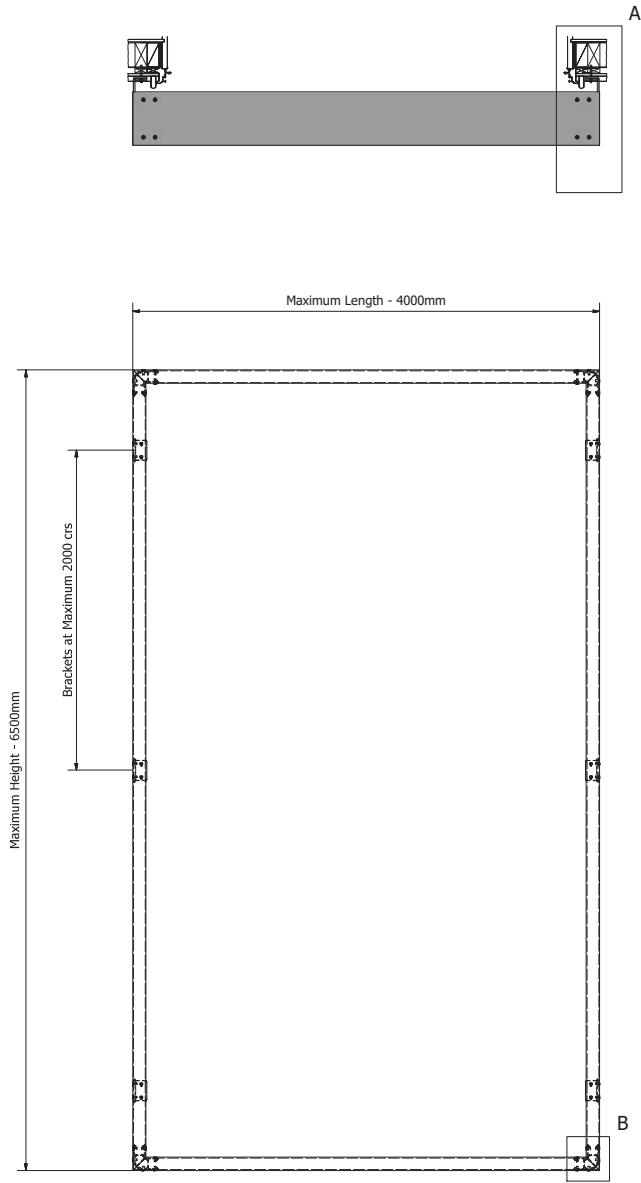

Frame Elevation 1:10

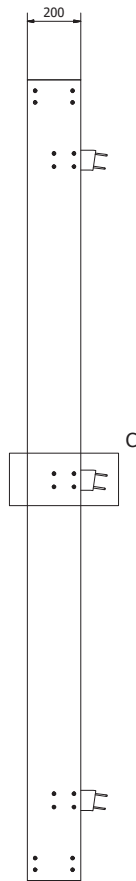

Detail C 1:2
Folded Bracket Detail

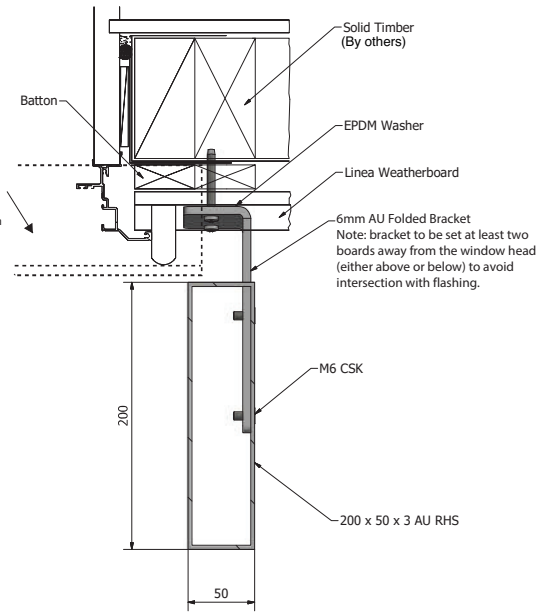

Detail A 1:2
Jamb Fixing Detail

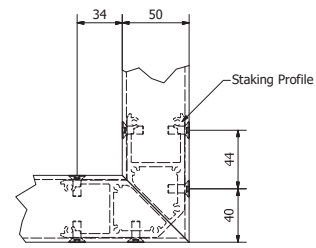

Detail B 1:2
Frame Corner Staking Detail

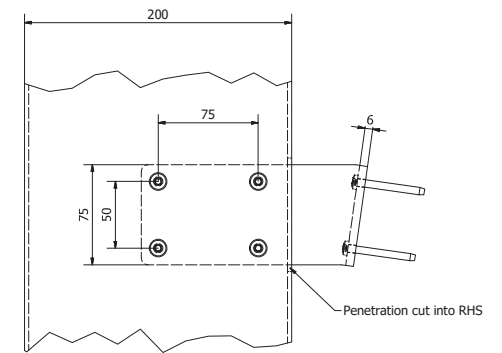

Detail C 1:2
Folded Bracket Detail

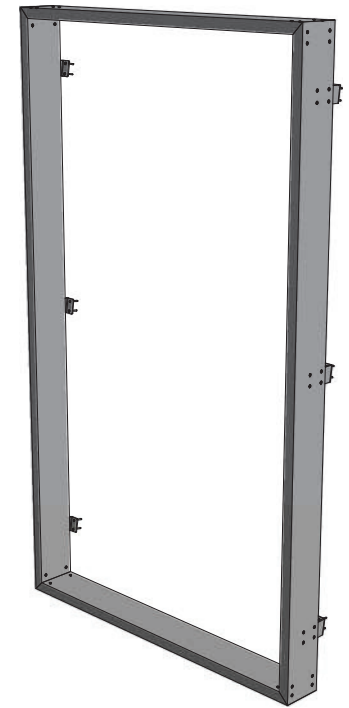

CHECKED AND APPROVED BY
BREVITY CONSULTING LTD
DATE: 22/02/2017
BREVITY REF: 16121908
REVISION: A



Revision Table			
Rev	Description	By	Date

Tolerance:
Dimension Decimal Places:
0 = +/- 1mm
0.0 = +/- 0.1mm
Angle = +/- 1°

*Unless otherwise stated. Do not scale. If in doubt ask.

File:
C:\Users\INSOL\Dropbox (Insol Ltd)\Insol\Product Information\Standard Details\Inventor Models\Window Hood Rear Mount Fixing Detail.Liam

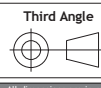

All dimensions are in mm unless otherwise stated

Material: N/A
Weight:
Finish:
Qty Req as Shown:
Qty Req Opp Hand:

INSOL Architectural Aluminium Louvres
P O Box 231, Invercargill
Free 0800 34 6000
Ph 216 3287
Fax 03 216 5928
www.insolnz.co.nz

Title:
Window Hood Standard Fixing Detail

Desc:
Weatherboard Bracket

Drawing No: IN-I -STDWH-1.1	Rev: A
Org Date: 1/12/2016	
Dwg By: DM	App By: DM
Scale: 1:10	
Project No: STDWH	A1

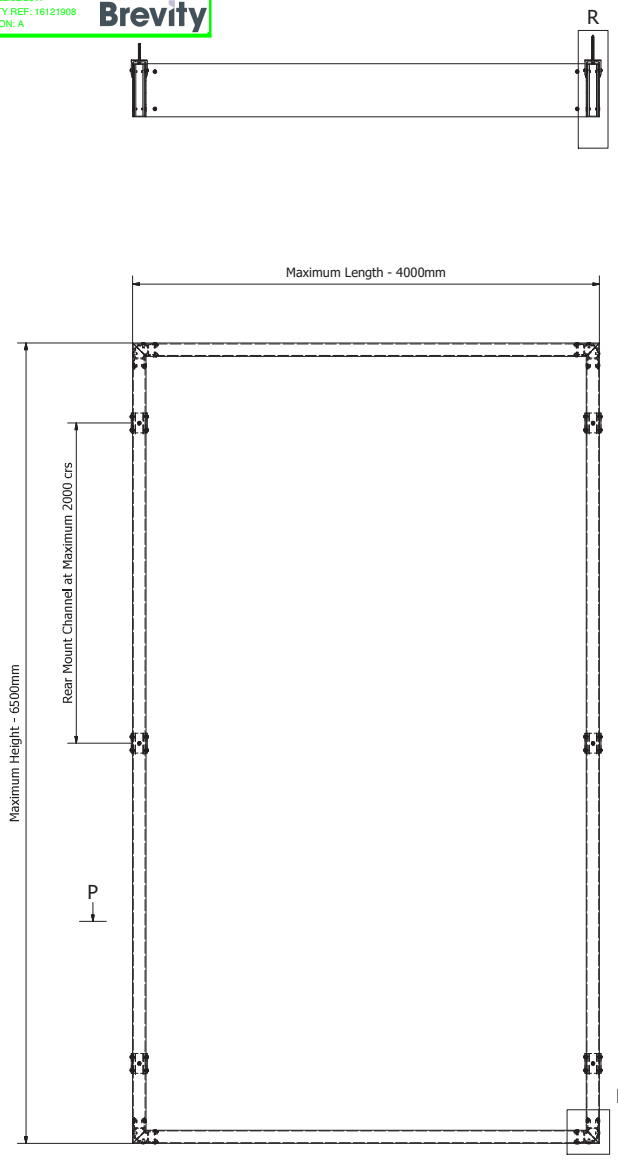

Frame Elevation 1:10

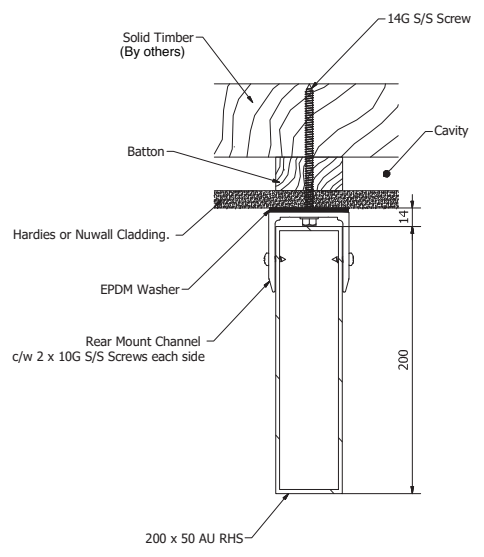

Detail C 1:2
Horizontal Fixing Detail

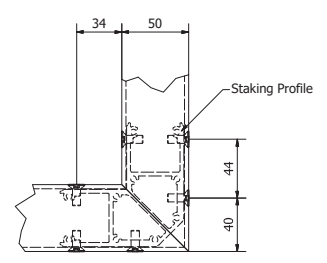

Detail B 1:2
Frame Corner Staking Detail

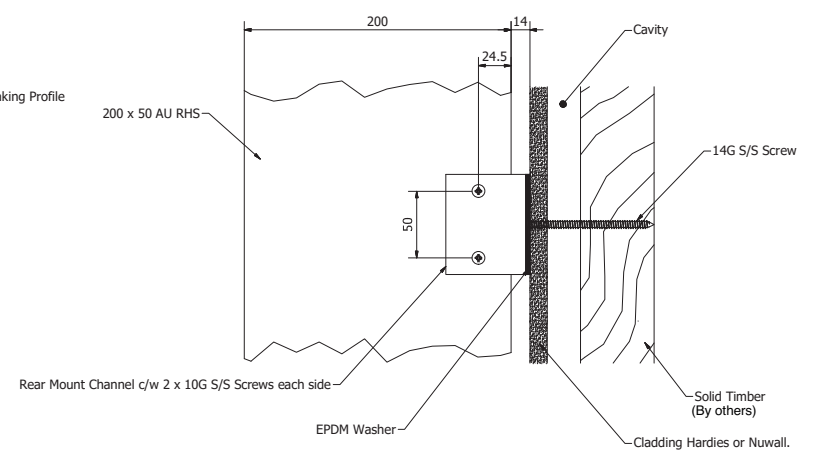

Detail D 1:2
Vertical Fixing Detail

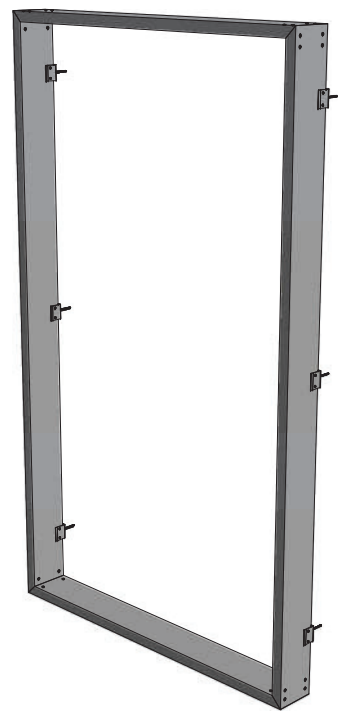

Revision Table			
Rev	Description	By	Date

Tolerance:
Dimension Decimal Places:
 0 = +/- 1mm
 0.0 = +/- 0.1mm
 Angle = +/- 1°

*Unless otherwise stated. Do not scale. If in doubt ask.

Third Angle

All dimensions are in mm unless otherwise stated

File:
 C:\Users\INSOL\Dropbox (Insol Ltd)\Insol\Product Information\Standard Details\Inventor Models\Window Hood RHS Frame Rear Mount.lam

Material: N/A
 Weight: N/A
 Finish: N/A
 Qty Req as Shown:
 Qty Req Opp Hand:

INSOL Architectural
 Facade Treatments

INSOL Architectural
 Aluminium Louvres

P O Box 231, Invercargill
 Free 0800 34 6000
 Ph 216 3287
 Fax 03 216 5928
 www.insolnz.co.nz

Title:
Window Hood Standard Fixing Detail

Desc:
Hardies & Nu-Wall Rear Mount Channel

Drawing No: IN-I -STDWH-1.2
 Rev: A

Org Date: 1/12/2016
 Dwg By: DM App By: DM
 Scale: 1:10
 Project No: STDWH **A1**

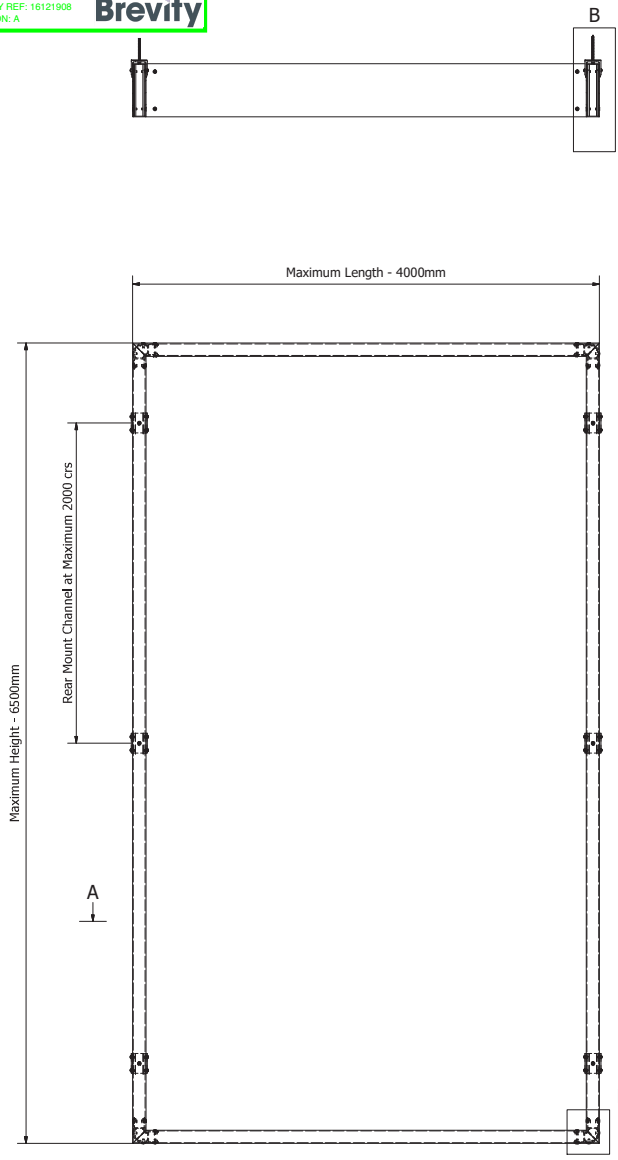

Frame Elevation 1:10

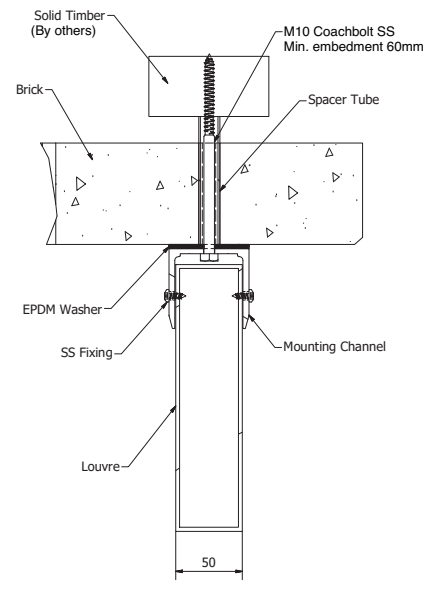
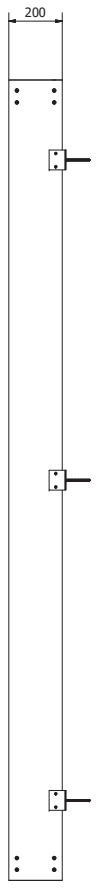

Detail C 1:2
Horizontal Fixing Detail

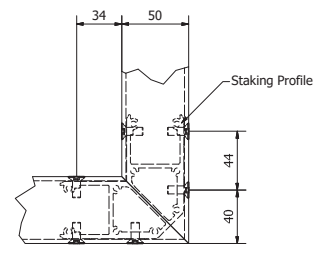

Detail B 1:2
Frame Corner Staking Detail

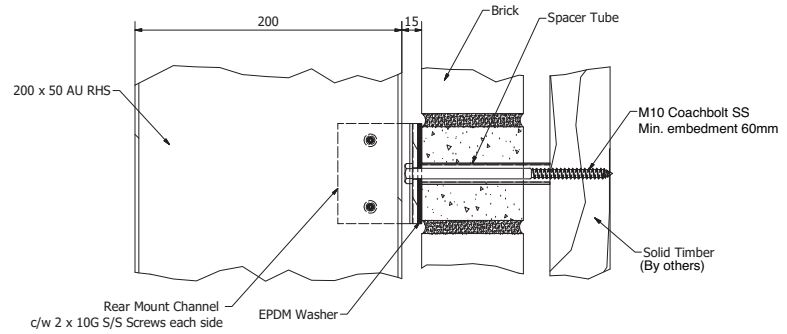

Detail D 1:2
Vertical Fixing Detail

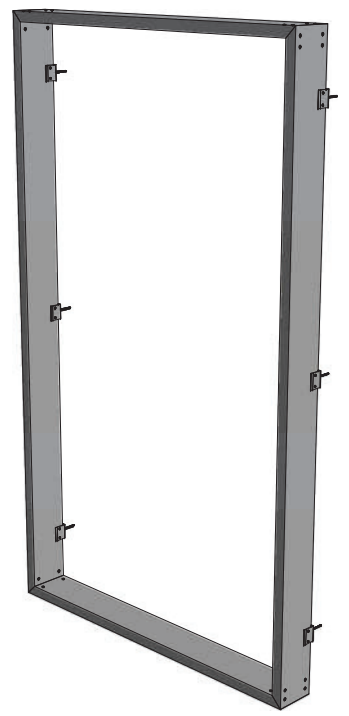

Revision Table			
Rev	Description	By	Date

Tolerance:
 Dimension Decimal Places:
 0 = +/- 1mm
 0.0 = +/- 0.1mm
 Angle = +/- 1°

*Unless otherwise stated. Do not scale. If in doubt ask.

File:
 C:\Users\INSOL\Dropbox (Insol Ltd)\Insol\Product Information\Standard Details\Inventor Models\Fletcher Living Window Hood Fixing.lam

Third Angle

All dimensions are in mm unless otherwise stated

Material: 213.753 kg
 Weight: 213.753 kg
 Finish:
 Qty Req as Shown:
 Qty Req Opp Hand:

INSOL Architectural Aluminium Louvres

P O Box 231, Invercargill
 Free 0800 34 6000
 Ph 216 3287
 Fax 03 216 5928
 www.insolnz.co.nz

Title:
Window Hood Standard Fixing Detail

Desc:
Brick Rear Mount Channel

Drawing No: IN-I -STDWH-1.3
 Rev: A

Org Date: 1/12/2016
 Dwg By: DM App By: DM
 Scale: 0.03 : 1
 Project No: STDWH **A1**

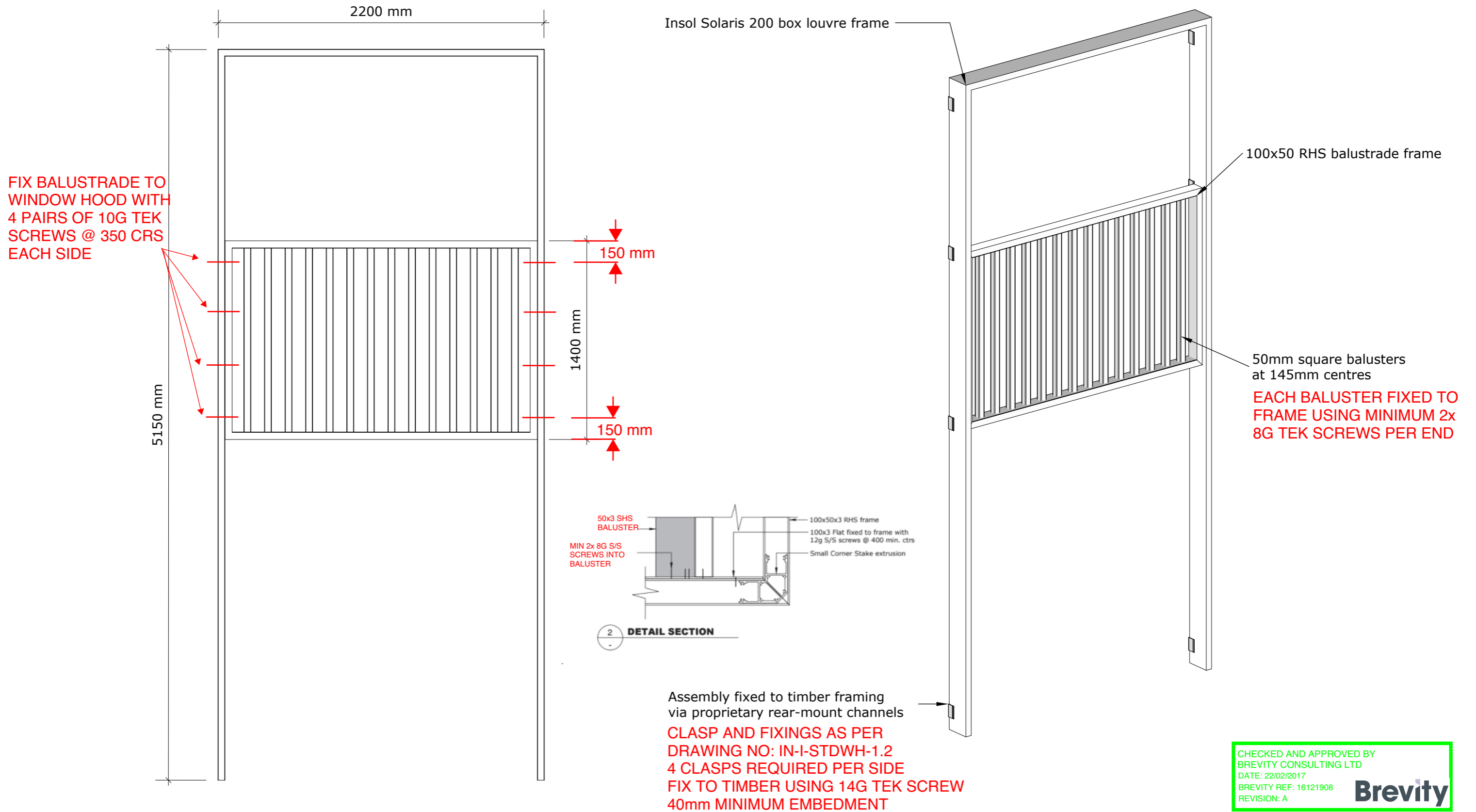

CHECKED AND APPROVED BY
 BREVITY CONSULTING LTD
 DATE: 22/02/2017
 BREVITY REF: 16121908
 REVISION: A



INSOL Architectural Aluminium Louvres
 PO Box 231, INVERCARGILL
 Free 0800 34 6000
 Ph 03 216 3287
 Fax 03 216 5928
 www.insolnz.co.nz

Catalina Precinct Fletcher Living
 Juliet Balustrade Concept

Date: 01/08/2017
 Revision: A
 Job No:
 Original Size: A3

Drawing No: **1**
 SCALE (N.T.S.)

ENGINEER Craig BVT JOB NUMBER 16121908
CLIENT Insol DATE 07/12/16 SHEET 1 OF 1

Hobsonville Canopies & Window Frames - Summary

- 2 Structure types:

- 1) Sheet metal (Al) Canopy supported by M8 Rods
- 2) 200x50x3 RHS frames surrounding windows.

- Load Cases:

- 1) $1.2G + W_u$ (down force)
- 2) $0.9G + W_u$ (uplift)

Structure 1) - Checked under LC1 & LC2

- ⇒ sheet metal tray checked in ANSYS, stress & δ minimal
- ⇒ Support Rod stresses low & Even an M6 rod wont buckle under LC2 therefore O.K (see SPL)
- ⇒ Connections checked in Persolve Calcs, all O.K

Structure 2)

- ⇒ Max bending in RHS; $f_b^* = 3.32 \text{ MPa}$ ⇒ Negligible
- ⇒ Bracket connections checked; $2 \times 10G$ taks to structure sufficient
- ⇒ Corner connections checked, 3.2mm rivets in shear sufficient.



16121908- INSOL - Hobsonville Canopy and Window Frames Design - Pensolve Calcs

Job number: 16121908.0

Calculations prepared by Craig MacDonald on December 5, 2016

From spreadsheet: 16121908- INSOL - Hobsonville Canopy and Window Frames Design - Pensolve Calcs.xlsx

Calculations reviewed by **Alex Merino** on **22/02/17**

Amended by A. Yung to include snow loads on 04/02/2019

Contents

1	Canopy	1
1.1	Calculations Updated 04.09.2019	1
1.2	Wind Actions	1
1.2.1	Finding C _{fig} as per Appendix D4.1	1
1.2.2	Design wind speed	1
1.2.3	Design Wind Pressure	1
1.2.4	Gravity Loads	2
1.2.5	Snow Loading to ASNZS 1170.3 (included 04.02.2019)	2
1.2.6	Load Cases	2
1.3	Connection Checks	2
1.3.1	Connection A - brace to Canopy	2
1.3.2	Connection B - Canopy to wall	3
1.3.3	Connection C- Brace to wall	3
1.4	Design Tension in tie brace	3
1.4.1	Allowable Stress in Tension brace for Canopy	4
1.5	Design Compression in tie brace	4
2	Louvre Screens	5
2.1	Wind Actions	5
2.1.1	Finding C _{fig} as per Appendix E	5
2.1.2	Design wind speed as per Section 2.3	5
2.1.3	Design Wind Pressure as per Section 2.4	5
2.2	Member Checks	6
2.2.1	200x50x3 RHS in weak axis bending	6
2.3	Connection Checks	6
2.3.1	Connection A- frame to wall	6
2.3.2	Connection A2 - shear in bracket	6
2.3.3	Connection B - Corner Connection	6

1 Canopy

1.1 Calculations Updated 04.09.2019

Inclusion of snow loads. Canopy design OK for snow regions N4, N5 at maximum height above mean sea level installation of 100 m or $S_g = 0.9$ kPa.

1.2 Wind Actions

Wind Actions to 1170.2 - canopy.

1.2.1 Finding C_{fig} as per Appendix D4.1

Single inputs	Value	Units	Comments	Cell Ref.
b	1.0	m	Width of canopy.	C8
l	1.0	m	Length of Canopy.	C9
K_a	1.0	-		C10
K_l	1.0	-		C11
$C_{p,n,d}$	0.5	-		C14
$C_{p,n,u}$	0.2	-		C15

*1170.2 Table D8
(downforce worstcase)
1170.2 Table D8 (uplift worstcase)*

$$\begin{aligned} h_c/h &= 0.4 \\ [C13] &= 0.4 \end{aligned} \qquad = \underline{0.4}$$

$$\begin{aligned} C_{fig,d} &= C_{p,n,d} \cdot K_l \cdot K_a \\ [C16] &= 0.5 \cdot 1.0 \cdot 1.0 \end{aligned} \qquad \begin{aligned} &1170.2 D4.1 \\ &= 0.5 \end{aligned}$$

$$\begin{aligned} C_{fig,u} &= C_{p,n,u} \cdot K_l \cdot K_a \\ [C17] &= 0.2 \cdot 1.0 \cdot 1.0 \end{aligned} \qquad \begin{aligned} &1170.2 D4.1 \\ &= 0.2 \end{aligned}$$

1.2.2 Design wind speed

Single inputs	Value	Units	Comments	Cell Ref.
C_{dyn}	1.0	-		C21
ρ_{air}	1.2	-		C22
V_R	45.0	m/s	V500.	C24
M_d	1.0	-	Directional multiplier - any direction.	C25
M_z	0.83	-	Terrain Height Multiplier - 5m.	C26
M_s	1.0	-	Not applicable.	C27
M_t	1.0	-	M_lee.	C28

*table 3.1
1170.2 Table 4.1
1170.2 4.3.1
1170.2 4.4.1b*

Design Wind Speed.

$$\begin{aligned} V_{des} &= V_R \cdot M_d \cdot M_z \cdot M_s \cdot M_t \\ [C30] &= 45.0 \cdot 1.0 \cdot 0.83 \cdot 1.0 \cdot 1.0 \end{aligned} \qquad = 37.4 \text{ m/s}$$

1.2.3 Design Wind Pressure

Design Wind Pressure from uplift.

$$\begin{aligned} W_u &= 0.5 \cdot \rho_{air} \cdot V_{des}^2 \cdot C_{fig,u} \cdot C_{dyn} \\ [C32] &= 0.5 \cdot 1.2 \cdot 37.4^2 \cdot 0.2 \cdot 1.0 \end{aligned} \qquad \begin{aligned} &1170.2 \text{ eq } 2.4(1) \\ &= 167.0 \text{ Pa} \end{aligned}$$

Design Wind Pressure from downforce.

$$\begin{aligned} W_d &= 0.5 \cdot \rho_{air} \cdot V_{des}^2 \cdot C_{fig,d} \cdot C_{dyn} \\ [C33] &= 0.5 \cdot 1.2 \cdot 37.4^2 \cdot 0.5 \cdot 1.0 \end{aligned} \qquad = 419.0 \text{ Pa}$$

1.2.4 Gravity Loads

Single inputs	Value	Units	Comments	Cell Ref.
$\rho_{Aluminium}$	2700.0	kg/m ³		C36
G [C37]	$= \rho_{Aluminium} \cdot 0.003$ $= 2700.0 \cdot 0.003$			= 8.1 Pa

1.2.5 Snow Loading to ASNZS 1170.3 (included 04.02.2019)

Single inputs	Value	Units	Comments	Cell Ref.
h_0	100.0	m	Height above NZ mean sea level, less than 400 m.	C40
k_P	1.25	-	1/150.	C41
α	0.0	degrees	Pitch.	C42
$s_{g,min}$	0.9	kPa	MBIE guidance document, amendment for N4, N5 regions.	C43
C_e	1.0	-	Exposure reduction coefficient, sub-alpine.	C45

Characteristic snow load.

$$s_g = k_P \cdot 1.2 \cdot \left(\frac{3 \cdot h_0}{1000} + 0.3 \right) = 1.25 \cdot 1.2 \cdot \left(\frac{3 \cdot 100.0}{1000} + 0.3 \right) = 0.9 \text{ kPa}$$

Shape coefficient.

$$\mu_i = \frac{0.7 \cdot (60 - \alpha)}{50} = \frac{0.7 \cdot (60 - 0.0)}{50} = 0.84$$

$$S = 1000 \cdot \text{MAX}(s_{g,min}, s_g) \cdot C_e \cdot \mu_i = 1000 \cdot \text{MAX}(0.9, 0.9) \cdot 1.0 \cdot 0.84 = 756 \text{ Pa}$$

1.2.6 Load Cases

$$1.2G + W_d(\text{down}) = (1.2 \cdot G + W_d) \cdot b \cdot l = (1.2 \cdot 8.1 + 419.0) \cdot 1.0 \cdot 1.0 = 428.0 \text{ N}$$

$$0.9G + W_u(\text{Up}) = (-0.9 \cdot G + W_u) \cdot b \cdot l = (-0.9 \cdot 8.1 + 167.0) \cdot 1.0 \cdot 1.0 = 160.0 \text{ N}$$

$$1.2G + S_u = (1.2 \cdot G + S) \cdot b \cdot l = (1.2 \cdot 8.1 + 756) \cdot 1.0 \cdot 1.0 = 766.0 \text{ N}$$

added 04.02.2019

1.3 Connection Checks

1.3.1 Connection A - brace to Canopy

Single inputs	Value	Units	Comments	Cell Ref.
$BoltDiameter$	6.0	mm		C59
$Althickness$	3.0	mm		C60

Note: M6 Bolt in shear due to $T=349N$.

Note: connection consists of an M6 SS Bolt through 3mm Al.

V* under 1.2G+s.g.

$$V_{[C61]}^* = N_{t^*, [C87]} = 349 \text{ N}$$

$$V^*, 1.2G + S_u = \frac{V^* \cdot 1.2G + S_u}{1.2G + W_d(\text{down})} = \frac{349 \cdot 766.0}{428.0} = 624.0 \text{ N}$$

Snow loading case, linear interpolation (added 04.02.2019)

$$\Phi V = 9000$$

$$[C63] = 9000$$

$$= \underline{9000} \text{ N}$$

$$f_{bearing} = \frac{V^*}{BoltDiameter \cdot Althickness}$$

$$[C65] = \frac{349}{6.0 \cdot 3.0}$$

$$= \underline{19.4} \text{ MPa}$$

$$f_{bearing,1.2G+S..} = \frac{V^* \cdot 1.2G + Su}{BoltDiameter \cdot Althickness}$$

Snow loading case, linear interpolation (added 04.02.2019)

$$[C66] = \frac{624.0}{6.0 \cdot 3.0}$$

$$= \underline{34.7} \text{ MPa}$$

$$\Phi F_{bearing} = 170$$

$$1664.1 \text{ CL } 3.4.6$$

$$[C67] = 170$$

$$= \underline{170} \text{ MPa}$$

Note: Demand far less than capacity therefore connection OK.

1.3.2 Connection B - Canopy to wall

Note: 10G Tek Screw into solid blocking.

ΦV . 6800.0. N. Ref: Buildex Tek Screw Catalogue. ΦT . 5700.0. N. Ref: Buildex Tek Screw Catalogue.

Note: Demand seen in SPL far less than capacity therefore connection OK.

1.3.3 Connection C- Brace to wall

Note: 10G Tek Screw into solid blocking.

ΦV . 6800.0. N. Ref: Buildex Tek Screw Catalogue. ΦT . 5700.0. N. Ref: Buildex Tek Screw Catalogue.

Note: Demand seen in SPL far less than capacity therefore connection OK.

1.4 Design Tension in tie brace

Single inputs	Value	Units	Comments	Cell Ref.
$N_{t^*}, [C87]$	349.0	N		C87

From ANSYS 1.2G + Wu case

$$A_{brace}, [C88] = \frac{\pi \cdot 8^2}{4}$$

$$[C88] = \frac{\pi \cdot 8^2}{4}$$

$$= 50.3 \text{ mm}^2$$

$$f_{t^*}, [C89] = \frac{N_{t^*}, [C87]}{A_{brace}, [C88]}$$

$$[C89] = \frac{349.0}{50.3}$$

$$= \underline{6.94} \text{ MPa}$$

$$N_{t^*}, [C91] = \frac{N_{t^*}, [C87] \cdot 1.2G + Su}{1.2G + W_d(down)}$$

Snow loading case, linear interpolation (added 04.02.2019)

$$[C91] = \frac{349.0 \cdot 766.0}{428.0}$$

$$= 624.0 \text{ N}$$

$$A_{brace}, [C92] = \frac{\pi \cdot 8^2}{4}$$

$$[C92] = \frac{\pi \cdot 8^2}{4}$$

$$= 50.3 \text{ mm}^2$$

$$f_{t^*}, [C93] = \frac{N_{t^*}, [C91]}{A_{brace}, [C92]}$$

$$[C93] = \frac{624.0}{50.3}$$

$$= \underline{12.4} \text{ MPa}$$

1.4.1 Allowable Stress in Tension brace for Canopy

Single inputs	Value	Units	Comments	Cell Ref.
Φ_y	0.95	-		C97
F_{ty}	110.0	MPa		C99

$$\begin{aligned} \Phi F_L &= F_{ty} \cdot \Phi_y \\ [C101] &= 110.0 \cdot 0.95 \end{aligned}$$

$$\begin{aligned} &1664.1 \text{ CL } 3.4.2 \\ &= \underline{105.0} \text{ MPa} \end{aligned}$$

Note: Demand far less than capacity therefore brace OK.

1.5 Design Compression in tie brace

Single inputs	Value	Units	Comments	Cell Ref.
N_{c^*}	49.0	N		C106

$$\begin{aligned} A_{brace, [C107]} &= \frac{\pi \cdot 8^2}{4} \\ [C107] &= \frac{\pi \cdot 8^2}{4} \end{aligned}$$

$$= 50.3 \text{ mm}^2$$

$$\begin{aligned} f_{t^*, [C108]} &= \frac{N_{c^*}}{A_{brace, [C107]}} \\ [C108] &= \frac{49.0}{50.3} \end{aligned}$$

$$= \underline{0.975} \text{ MPa}$$

Note: See SPL - Even in a 6mm diameter rod no buckling will occur and stress minimal.

2 Louvre Screens

2.1 Wind Actions

Wind Actions to 1170.2 E - Exposed structural members.

2.1.1 Finding C_{fig} as per Appendix E

Single inputs	Value	Units	Comments	Cell Ref.
<i>b</i>	200.0	mm	Width of member.	C8
<i>d</i>	50.0	mm	depth of member.	C9

Max Length of member.

$$L = 4250$$

[C10] = 4250

= 4250 m

$$\frac{d}{b} = \frac{50.0}{200.0}$$

[C11] = 0.25

= 0.25

$$C_{fx} = 2.4$$

[C12] = 2.4

1170.2 table E2A
= 2.4

$$C_{fy} = 0.5$$

[C13] = 0.5

1170.2 table E2B
= 0.5

$$\frac{L}{b} = \frac{4250}{200.0}$$

[C14] = 21.3

= 21.3

$$K_{ar} = 0.83$$

[C15] = 0.83

1170.2 table E1
= 0.83

$$C_{fig} = C_{fx} \cdot K_{ar} \cdot 1$$

[C16] = 2.4 · 0.83 · 1

1170.2 Eq E2(2)
= 1.99

2.1.2 Design wind speed as per Section 2.3

Single inputs	Value	Units	Comments	Cell Ref.
<i>C_{dyn}</i>	1.0	-		C18
<i>ρ_{air}</i>	1.2	-		C19
<i>V_R</i>	45.0	m/s	V500.	C21
<i>M_d</i>	1.0	-	Directional multiplier - any direction.	C22
<i>M_z</i>	0.83	-	Terrain Height Multiplier - 5m.	C23
<i>M_s</i>	1.0	-	Not applicable.	C24
<i>M_t</i>	1.0	-	M _{lee} .	C25

Design Wind Speed.

$$V_{des} = V_R \cdot M_d \cdot M_z \cdot M_s \cdot M_t$$

[C27] = 45.0 · 1.0 · 0.83 · 1.0 · 1.0

= 37.4 m/s

2.1.3 Design Wind Pressure as per Section 2.4

Design Wind Pressure.

$$p = 0.5 \cdot \rho_{air} \cdot V_{des}^2 \cdot C_{fig} \cdot C_{dyn}$$

[C29] = 0.5 · 1.2 · 37.4² · 1.99 · 1.0

1170.2 eq 2.4(1)
= 1670.0 Pa

2.2 Member Checks

2.2.1 200x50x3 RHS in weak axis bending

Single inputs	Value	Units	Comments	Cell Ref.
I	706000.0	mm ⁴		C34

$$M^* = \frac{p \cdot b}{1000} \cdot 1.5^2 = \frac{1670.0 \cdot 200.0}{1000} \cdot 1.5^2 = 93.8 \text{ Nm}$$

$$fb^* = \frac{M^* \cdot 1000 \cdot 25}{I} = \frac{93.8 \cdot 1000 \cdot 25}{706000.0} = 3.32$$

Note: Bending Stress due to wind is minimal.

2.3 Connection Checks

2.3.1 Connection A- frame to wall

Note: connection consists of 2x10G tek screws 3 connections per side of frame.

Shear in Tek screw fixing frames to wall.

$$V_{[C44]}^* = \frac{p \cdot b \cdot L}{1000} = \frac{1670.0 \cdot 200.0 \cdot 4250}{1000 \cdot 6} = 236.0 \text{ N}$$

From Buildex Catalogue.

$$\Phi V_{[C45]} = 6800 = 6800 \text{ N}$$

Note: Demand well below capacity therefore OK.

2.3.2 Connection A2 - shear in bracket

$$V_{[C49]}^* = V_{[C44]}^* \cdot 2 = 236.0 \cdot 2 = 472.0 \text{ N}$$

$$t_{bracket} = 6 = 6 \text{ mm}$$

$$d_{bracket} = 75 = 75 \text{ mm}$$

$$f_{shear} = \frac{V_{[C49]}^*}{t_{bracket} \cdot d_{bracket}} = \frac{472.0}{6 \cdot 75} = 1.05 \text{ MPa}$$

2.3.3 Connection B - Corner Connection

Single inputs	Value	Units	Comments	Cell Ref.
d_{rivet}	3.2	mm		C56

Note: connection consists of 3 rivets per member into staking angle.

$$F_{member} = \frac{p \cdot b \cdot 1600}{1000} = \frac{1670.0 \cdot 200.0 \cdot 1600}{1000} = 534.0 \text{ N}$$

$$V_{rivet}^* = \frac{F_{member}}{3} = \frac{534.0}{3} = 88.9 \text{ N}$$

$$f_v = \frac{V_{rivet}^*}{\pi \cdot d_{rivet}^2} = \frac{88.9}{\pi \cdot 3.2^2} = 11.1 \text{ MPa}$$

Note: Minimal shear stress in all connections therefore OK.

Brevity

+64 9 216 7104

www.teambrevity.com

Hobsonville Canopy

3mm Sheet metal Al canopy

Model

Beam and Surface model set up in SC. thickness = 3mm diameter of rod = 10mm

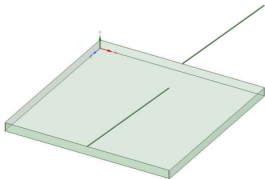

Setup - ANSYS 17

Mesh and 1.2G + Wu setup

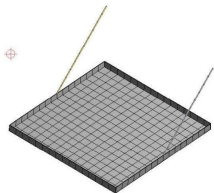

Static Structural
Static Structural
Time: 1. s
06/12/2016 10:58:00

- A** Acceleration: 11733 mm/s²
- R** Pressure: 4.185e-004 MPa
- S** Simply Supported: 8 mm
- S** Simply Supported: 2.0 mm
- S** Remote Displacement
- S** Remote Displacement 2

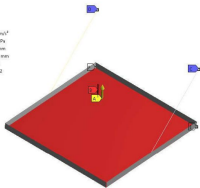

Results - Sheet metal

Deflection and stress allowable

Static Structural
Equivalent Stress
Type: Equivalent (von-Mises) Stress - Tqz010006
Unit: MPa
Time: 1
26/11/2016 11:00:00 AM

30.011 Max
29.199
25.636
11.751
10.071
11.106
11.100
0.0019
4.3401
1.9117 Min

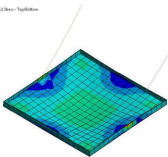

Static Structural
Total Deformation
Type: Total Deformation
Unit: mm
Time: 1
26/11/2016 11:00:00 AM

18.675 Max
8.9554
7.088
6.7146
5.5871
4.8777
3.5540
2.2589
1.1194
0 Min

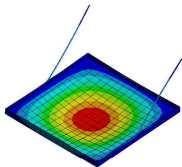

Results - Tie Rods

El Static Structural

Maximum Combined Stress
Type: Maximum Combined Stress - Top/Bottom
Unit: MPa
Time: 1
09/12/2016 11:01 AM

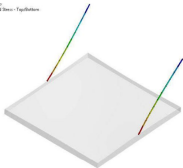

El Static Structural

Axial Force
Type: Directional Axial Force(Ax) (Displacement)
Unit: N
Solution Coordinate System
Time: 1
09/12/2016 11:02 AM

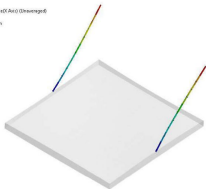

Results - Fixing reactions

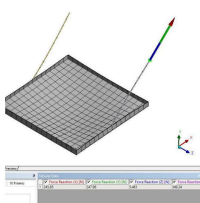

Static Structural
Force Reaction 3
20/11/2016 11:01 AM

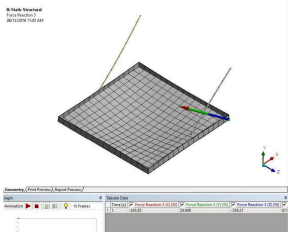

Compression in Rod under 0.9G + uplift

8) Static Structural
Static Structural
Time: 1 s
06/10/2016 11:06:04

- Acceleration: 8829 mm/s²
- Simply Supported: 0 mm
- Simply Supported: 0 mm
- Remote Displacement: 2
- Remote Displacement: 2
- Pressure: 2, 1.67e-004 MPa

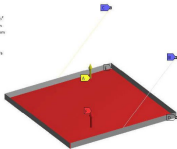

8) Static Structural
Axial Force
Type: Directional Axial Force (K,Ref) (Skewwarp)
Unit: N
Solution Coordinate System
Time: 1
06/10/2016 11:07:04

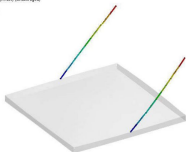

Compression in Rod under 0.9G + uplift

B: Static Structural

Maximum Combined Stress

Type: Maximum Combined Stress - Top/Bottom

Units: MPa

Time: 1

06/12/2016 11:07 AM

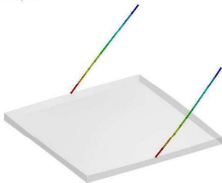

C: Eigenvalue Buckling

Total Deformation

Type: Total Deformation

Load Multiplier: 45.005

Units: mm

06/12/2016 11:09 AM

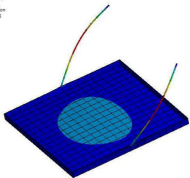

Compression in Rod under 0.9G + uplift 6mm rod

Stress still minimal and will not buckle with 6mm rod

B: Static Structural

Maximum Combined Stress
Type: Maximum Combined Stress - Top/Bottom
Unit: MPa
Time: 1
06/12/2016 11:12 AM

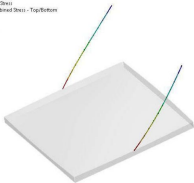

C: Eigenvalue Buckling

Total Deformation
Type: Total Deformation
Load Multiplier: 1.6723
Unit: mm
06/12/2016 11:11 AM

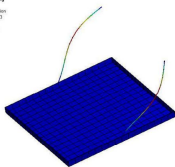

Date : 09/08/17

Job No. : 16121908-03

Project Title : Hobsonville Canopy and frame - balustrade addition

Prepared for : INSOL

Prepared by : Alex Merino

Approved by : Matt Bishop

Overview

- Purpose of this project is to add a balustrade design to the existing window hood
- Generic PS1 issue valid for 12 months
- AxisVM beam analysis of balustrade added to existing window hood design
 - Utilising beams/sections/model from previous PS1 calcs for speed.

Methodology

- AxisVM - Beam models
- 1664.1 Limit state used - Bending stress limit: 98 MPa
- Loads applied:
 - G
 - $Q_p = 600\text{N}$
 - $Q_{udl} = 0.75\text{kN/m}$
 - $Q_{press} = 1\text{ kPa}$
- Load combinations all checked under $1.2G+1.5Q$

Model/Analysis Setup

- Pinned connections at all wall interfaces
- Rigid links at screw locations between balustrade and louvre
- Forces applied are from 1170 for balustrade/handrail loads
- Run in linear and nonlinear just to check, difference is negligible as material is nowhere near yield.

Results - tek screws to structure - 14G in timber

40mm embedment required based on withdrawal load calc

Worst case shear in anchors: 0.4kN

Worst case pull out in anchors: 1.1kN

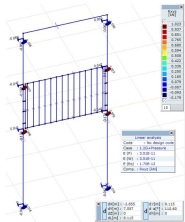
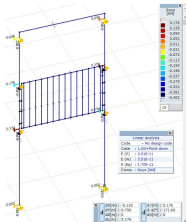

Results

Peak deflection @ULS: 3.3mm OK
L/500 = 4.2mm

Stress max @ ULS: 22.5MPa OK
Allowable: 98 MPa

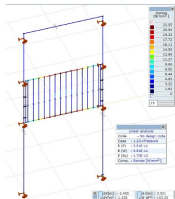
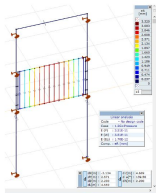

Results

Shear in fixings between balustrade and louvre
More for a sanity check than anything else.
Connections OK with 2x 10G tek screws at each point

Stress plot of balustrade top beam @ ULS

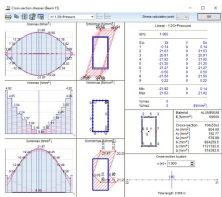
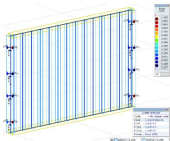

BUILDING SUPPORTING CHECK (ALUMINIUM CANOPY).

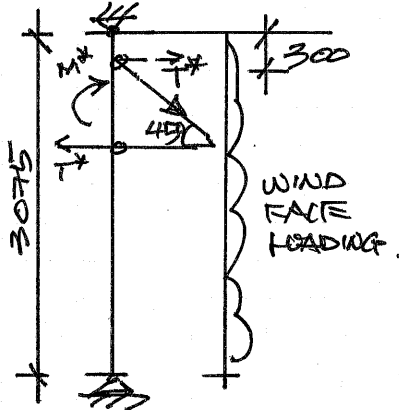

ROD TENSION (CRITICAL CASE).

$$T^* = 0.35 \text{ kN (BVT CALS. PAGE 4/8)}$$

HORIZONTAL PULL OUT FORCE

$$T_H^* = T^* \cos 45^\circ$$

$$= 0.35 \text{ kN} \times 0.707$$

$$= 0.25 \text{ kN}$$

$$M^* = 0.1 \text{ kN.m} + \frac{1}{8} \times W_F^* \times 0.4 \times 3.075^2 \text{ (FACE WIND LOAD)}$$

$$= 0.38 \text{ kN.m}$$

$$\phi M_u = 0.8 \times 0.8 \times 1123 \times 1.0 \times 14000 \times 0.04 \times 0.09^2 / 6$$

$$= 1123 \text{ kN.m} > M^* = 0.38 \text{ kN.m. OK.}$$

$$W_F^* = 0.5 \times 112 \times (3.075^2) \times 0.7 = 0.59 \text{ kPa}$$

SERVICEABILITY:

$$W_s = 0.676 W_u$$

$$\Delta = 0.67 \times 0.005 = 0.004 \text{ m} = 4 \text{ mm} < \frac{1}{400} = 7.68 \text{ mm OK}$$

USE 2/90x45 SGB DOUBLE STUDS AS BUILDING SUPPORTING MEMBER TO ROD TIE FIXING, WITH PAIR OF MULTI GRAP CONNECTION TOP & BOTTOM OF THE STUDS.

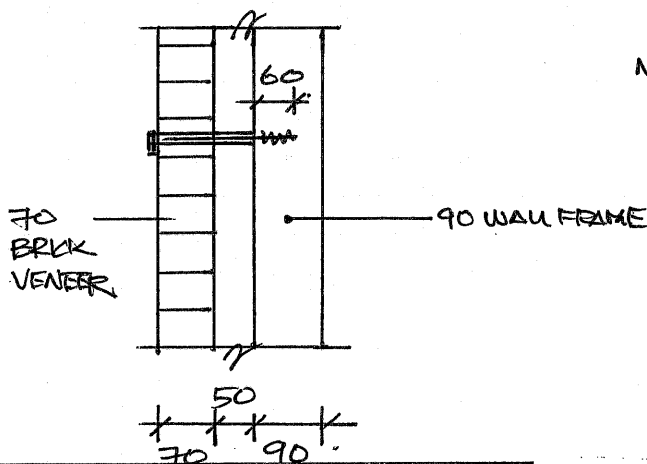

NEED M10 COACH SCREW x 180 LG. MW. 60mm INTO DOUBLE STUDS.

$$\phi Q_u = 0.7 \times 0.8 \times 110 \times 1.0 \times 0.107 \times 60$$

$$= 3.0 \text{ kN} > T_H^* = 0.25 \text{ kN OK.}$$

USE M10 COACH SCREW x 180 MM LG FOR THE FIXING OF THE ROD CLEVIS BACK TO EXTERNAL WALL WITH 70 SERIES BRICK VENEER.

BUILDING SUPPORTING CHECK (ALUMINIUM LOWERS WITH BALUSTRADE),

DESIGN LOAD FROM BUT CALCULATION PAGE.

WORST CASE PULLOUT IN ANCHORS: 111 kN.

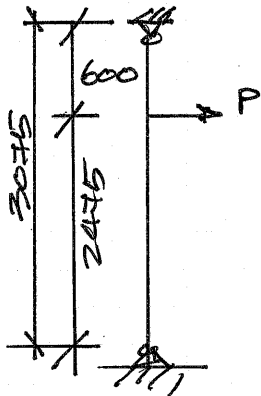

BENDING

$$M^* = 111 \times 0.6 \times 2.475 / 3.075 = 0.53 \text{ kN.m}$$

$$\begin{aligned} \phi M_u &= 0.8 \times 110 \times 113 \times 110 \times 14000 \times 0.09 \times 0.09^2 / 6 \\ &= 1154 \text{ kN.m} > M^* \text{ OK.} \end{aligned}$$

USE M10 COACHSCREW X 180mm MIN. 50mm INTO DOUBLE STUDS

$$\begin{aligned} \phi Q_u &= 0.7 \times 0.85 \times 110 \times 110 \times 0.107 \times 50 \\ &= 3.2 \text{ kN} > P^* = 11 \text{ kN} \text{ OK.} \end{aligned}$$

SERVICEABILITY: $E_s = 0.25 E_u$

$$= 0.25 \times 11 = 0.275 \text{ kN.}$$

$$\Delta E_s = 22 \text{ mm} < \frac{1}{600} = \frac{3075}{600} = 5.1 \text{ mm OK.}$$

USE M10 COACHSCREW X MIN. 180mm LG AS HORIZONTAL FIXING BACK TO EXTERNAL WALL WITH BRICK VENEER.