

AURAE TECHNICAL DATA SHEET

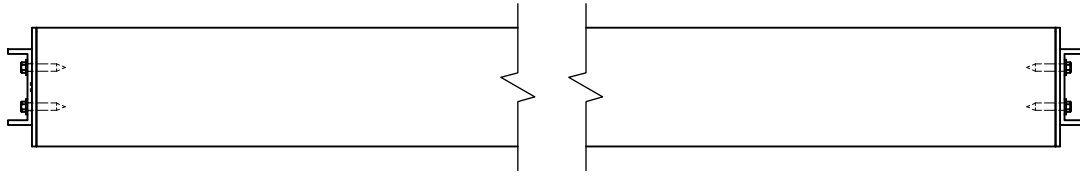

PLAN VIEW

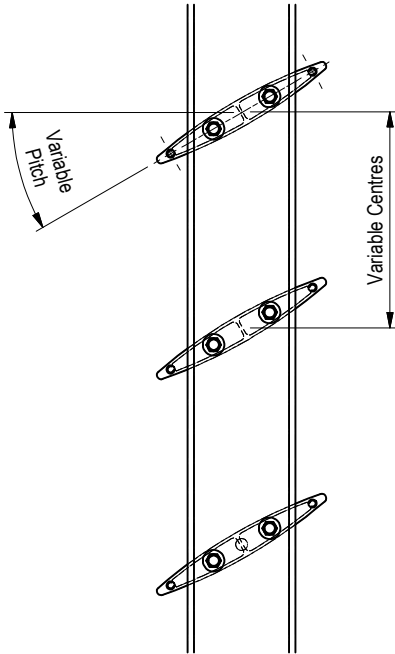

END FIXING DETAIL

Configuration and layout:

- The louvre blades can be set at any centres.
- Blade angle can be set at any degree of pitch between completely flat and 90° vertical.
- Once the degree of pitch has been decided upon and the louvres are installed, the angle of the blades is fixed and cannot be changed.

Assembly and Installation:

- The louvre blades are fixed to the side channels with stainless 10gx19 self-tapping screws.
- The size of the side channel can be varied to suit individual project requirements. If required, the channel can be substituted for an aluminium flat bar, angle or box section.

Structural Requirements:

- The length of the louvre blade must be within the span appropriate to the wind loading on the louvre blade. See Span Data Table for spans relative to wind zones.
- The fixing detail of the side channel to the main support structure varies dependent on the type of structure. Contact Insol for project specific recommendations.

Componentry and Finishes:

- All the aluminium components (the louvre blade, end caps and side channel) can be finished with any exterior powder coat or grade of anodising.
- Any louvre blades that are too wide to be covered by the side channel are fitted with a 3mm end cap, finished to match the louvre.
- If the louvre blade can fit within the width of the side channel (i.e. if a side channel is used that is larger than the louvre blade, or if the louvre blades are on a steep enough angle) no end cap is required.
- All fixings are stainless steel.

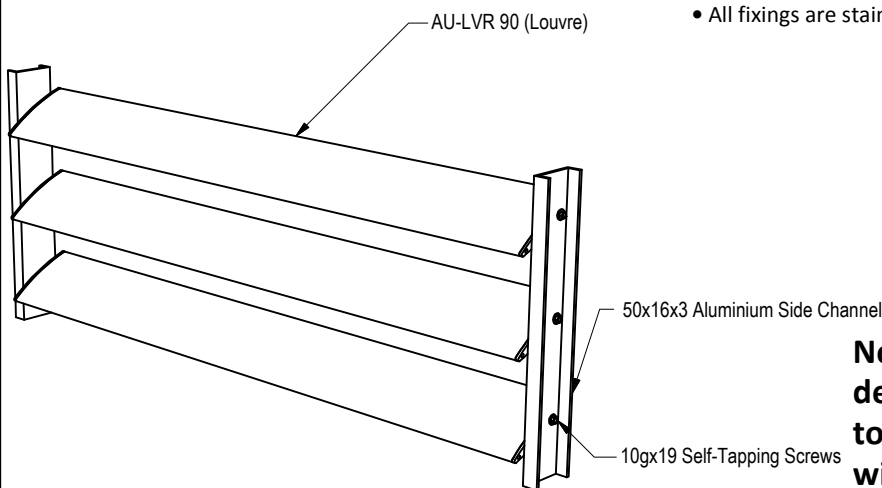

Pictorial

Not sure if this is the correct fixing detail for your project? Contact Aurae to discuss your requirements - we will be able to recommend the most suitable fixing methods for your specific scenario.

**AURORA™ 90
END FIXING TO CHANNEL**



© 2018 All rights reserved
Aurae Ltd
Ph: +64 9 218 8690
E: sales@aurae.co.nz
www.aurae.co.nz

Scale: N.T.S.
Date: 7/03/2014

AU-LVR 90 EF Ver. 1