

AURAE TECHNICAL DATA SHEET

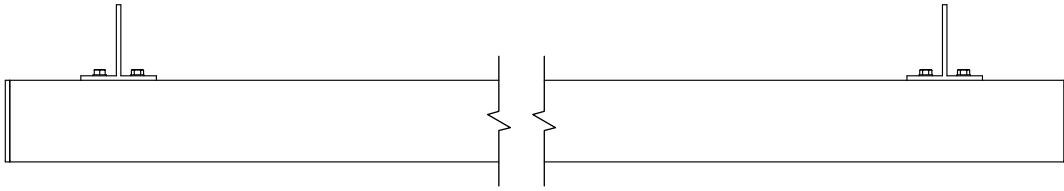

PLAN VIEW

Configuration and layout:

- The louvre blades can be set at any centres.
- Blades can be set on either 45° upward or 45° downward tilt.

Assembly and Installation:

- The louvre blades are fixed through the rear of the tee-section support with stainless 8gx12 self-tapping screws.
- The size and profile of the support rails can be varied to suit individual project requirements. If required, the tee-section can be substituted for an aluminium flat bar, angle or box section.

Structural Requirements:

- Support rails are required at centres appropriate to the wind loading on the louvre blade. See Span Data Table for spans relative to wind zones.
- The fixing detail of the tee-section support rail to the main support structure varies dependent on the type of structure. Contact Aurae for project specific recommendations.

Componentry and Finishes:

- All the aluminium components (the louvre blade, end caps and support rail) can be finished with any exterior powder coat or grade of anodising.
- Exposed ends of the louvre blades are fitted with a 3mm aluminium end cap, finished to match the louvre.
- All fixings are stainless steel.

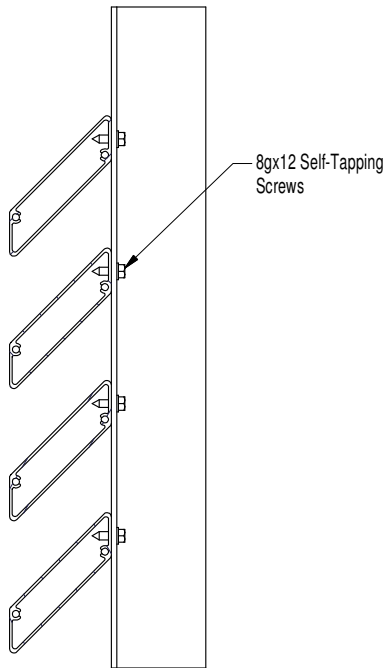

SECTIONED VIEW

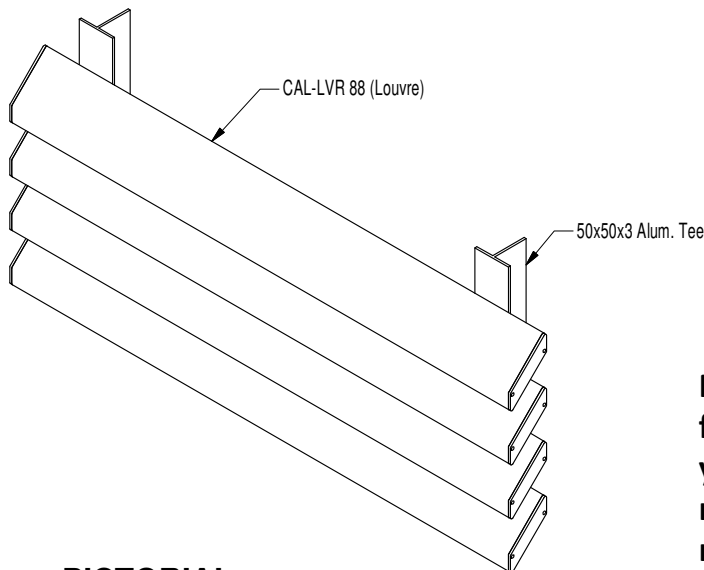

PICTORIAL

Not sure if this is the correct fixing detail for your project? Contact Aurae to discuss your requirements - we will be able to recommend the most suitable fixing methods for your specific scenario.

CALDERA™ 88
REAR FIXED



© 2018 All rights reserved
Aurae Ltd
Ph: +64 9 218 8690
E: sales@aurae.co.nz
www.aurae.co.nz

Scale: N.T.S.
Date: 22/07/2014

CAL-LVR 88 RF Ver. 1