

# AURAE TECHNICAL DATA SHEET

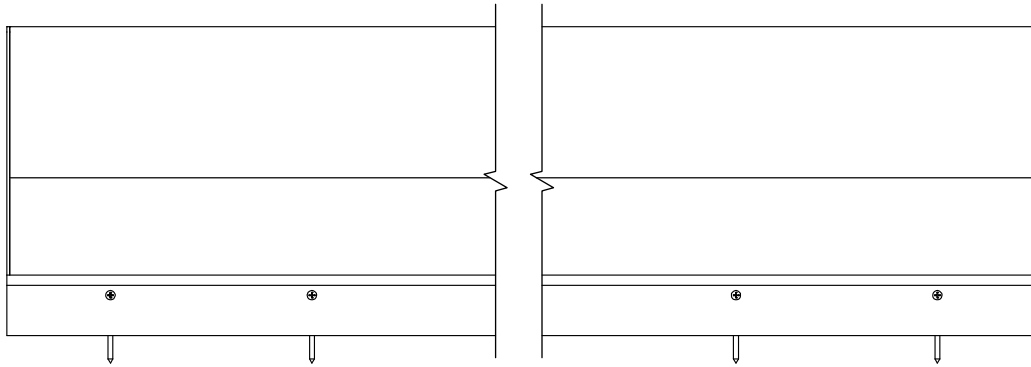

**PLAN VIEW**

**Configuration and layout:**

- The louvre blades can be set at any centres.
- Blade angle is restricted to 90° from the support structure surface.

**Assembly and Installation:**

- The louvre blades are fixed to the rear channels with stainless 10gx19 self-tapping screws.

**Structural Requirements:**

- The fixing detail of the rear channel back to the main support structure varies dependent on the type of structure and wind loadings on the louvre. Contact Aurae for project specific recommendations.

**Componentry and Finishes:**

- All the aluminium components (the louvre blade, end caps and channel) can be finished with any exterior powder coat or grade of anodising.
- All fixings are stainless steel.

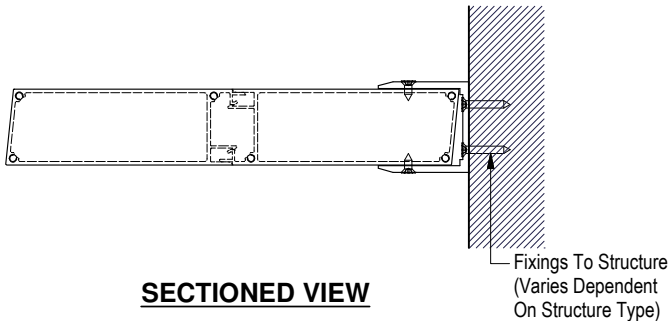

**SECTIONED VIEW**

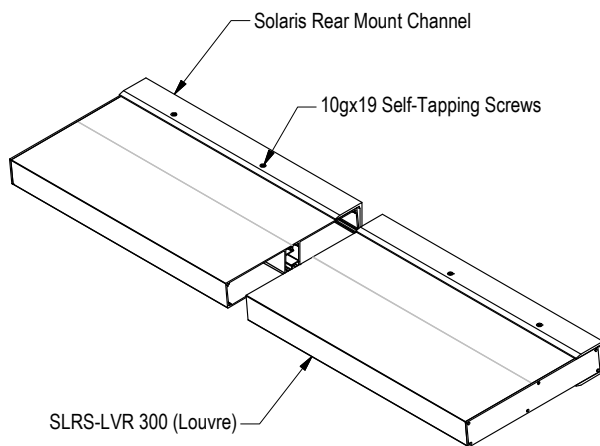

**Pictorial**

**Not sure if this is the correct fixing detail for your project? Contact Aurae to discuss your requirements - we will be able to recommend the most suitable fixing methods for your specific scenario.**

**SOLARIS™ 300  
REAR CHANNEL MOUNTED**



© 2018 All rights reserved  
Aurae Ltd  
Ph: +64 9 218 8690  
E: sales@aurae.co.nz  
www.aurae.co.nz

Scale: N.T.S.  
Date: 4/03/2014

SLRS-LVR 300 RCM Ver. 1